

LED Resistor Professional 150

50W | 5 Jahre Garantie | IP66

Bestellnummer: KM-RP050-L150

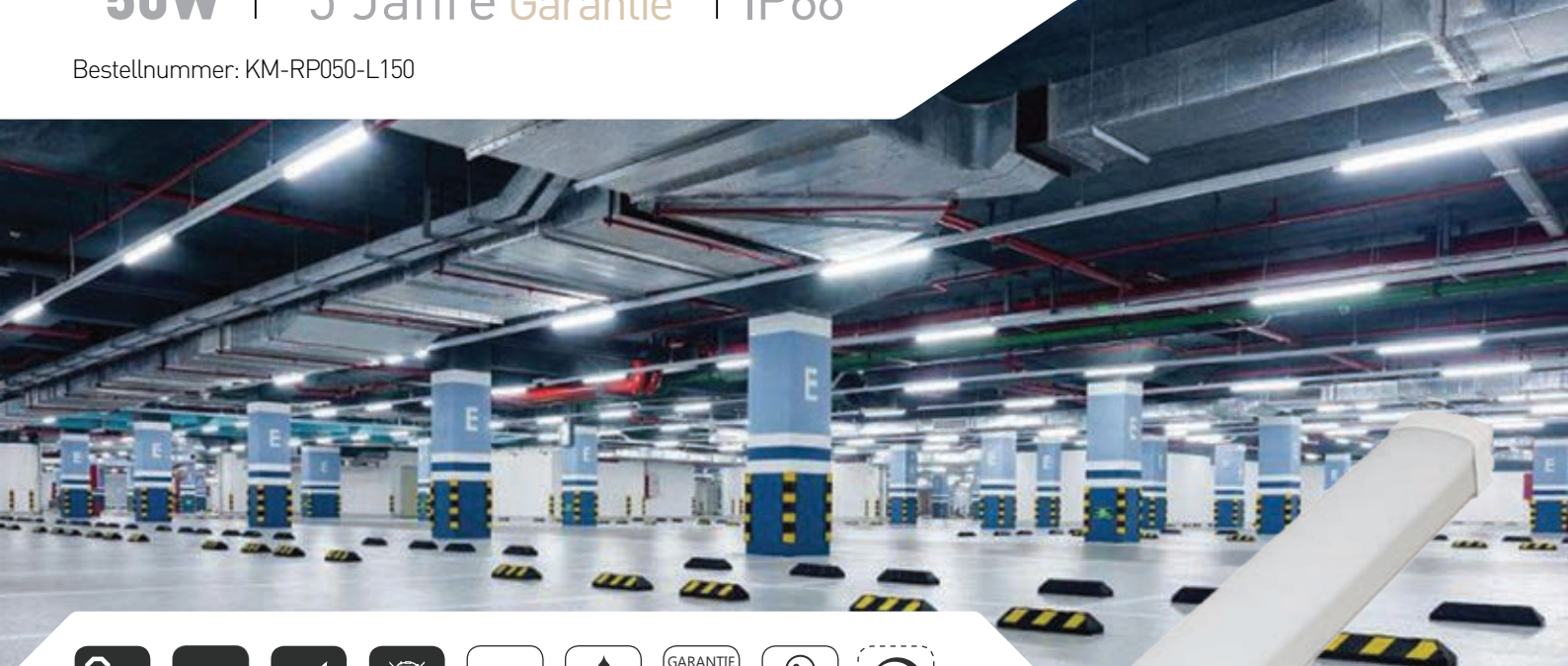

EINSATZGEBIETE

Ideal für Tiefgaragen, Autowashstraßen, Parkhäuser und vieles mehr.



MAßE

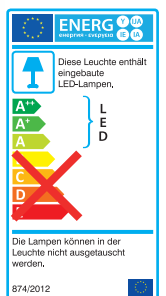
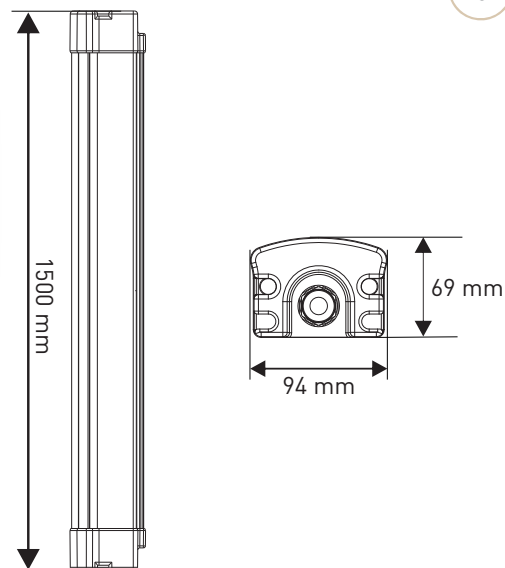

FEUCHTRAUMLEUCHTEN

OPTIK UND ELEKTRIK



Nennleistung	50W
Farbtemperatur	3000K/4000K/5000K
Lichtstrom	6750(±5%)lm
Effizienz	135(±5%)lm/W
Farbwiedergabe/CRI	>80
Abstrahlwinkel	120°
Optionale Funktionen	1-10V, DALI, Traffic, Notlicht, Mikrowellensensor
LED Lebensdauer	>50.000 Std.



MECHANIK

Betriebstemperatur	-20°C bis +45°C
Maße (HxBxT)	94 x 1500 x 69 mm
Gewicht	3kg
Montage Optionen	Hänge-Set Aufbau



ZUBEHÖR



HÄNGE-SET
1m: KM-Z-RP001

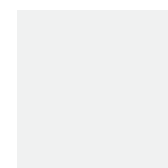
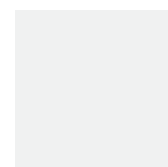
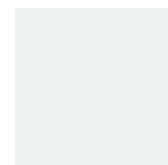
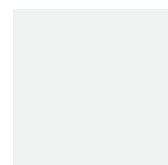

LIEFERUMFANG

Leuchtkörper, Halterung,
Schrauben-Set



LICHTKURVE

